



Congratulations on the purchase of one of the world's handiest audio products. Able to buffer USB from your computer for low-jitter smoothness; able to strip S/PDIF digital data from optical or coax inputs in a single flick of a switch; able to source a sweet analog signal for your favorite headphone or speaker based back-end ...it's Super Micro DAC! Okay, so we got a bit carried away, but so will you when your digital music so wonderfully fills that space right between your ears.

Either way you go, you're getting the best DAC in Cirrus Logic's lineup; some of the finest metal-film resistors and poly caps money can buy; and a perfectly lovely way to get great sound without burning up valuable desktop real estate. But enough of this chatter! Read on, hook up, and bliss out to your music. You deserve your reward for money well spent!

## The Micro DAC Front Panel

The front panel of the Micro DAC is short, sweet, and elegant; one simple set of input switches and another power switch along with the HeadRoom logo-LED are all the grace that front of this simple unit.



## The Micro DAC Front Panel Descriptions

**1. Input Selector Switch** choose between your digital inputs here. The input selector switch allows you to have multiple digital sources plugged in to your Micro DAC all at one time. You can easily switch between your sources by simply flipping this switch to the corresponding input you'd like to hear; either USB, coax, or optical. Be sure to turn the volume down before switching between various inputs until you grow accustomed to any volume level changes that may occur with varying source impedances.

**2. Power Switch** When the power is set to 'on'; the red LED will illuminate in the center of the HeadRoom logo in the upper left hand corner of the amp. There is nothing wrong with leaving your amp 'on' or 'off' for lengthy periods of time; however we recommend that you unplug your amplifier if you're storing it for a long period of time.



Included Power Supply

## The Micro DAC Rear Panel

On the back of the unit you will find a line output, external power input, and three digital inputs: optical, coaxial, and USB.



## The Micro DAC Rear Panel Descriptions

**1. Line Output** The line out is the best sounding stereo-mini plug out there. This is the signal source you plug into the input of your headphone amp. You will need a mini-mini cable to plug from the Micro DAC into the Micro Amp or other amplifier with a line input. HeadRoom sells various mini-mini cables; we highly recommend one of varying lengths offered by Cardas. You can also use this output to connect your Micro DAC to another amplifier, home stereo receiver, or home theater system.

**2. Optical Input** The optical input is the first of the digital inputs we'll discuss on the Micro DAC, and uses your typical Toslink connector. You get this input signal from the optical output of your player. Not so many portable audio players have optical outputs, but many portable DVD players and some hard disk drive players do. Of course, you can get this signal from many pieces of home equipment.

**3. External+/- 15VDC Power Input** Plug in your power supply here. The 'brick' power supply is included with the Micro DAC; upon purchase you will have chosen a voltage appropriate to your country's voltage requirement, either 110v (North America, Japan, Singapore and others) or 220v (Europe, Australia, China, etc). We also recommend the Astrodyne switching power supply or the larger Desktop Power Supply (both accommodate any country's voltage requirement) as available power upgrades, these upgrades are particularly useful with the Micro DAC. Visit our website for more information about these power supply upgrades.

**4. Coaxial Input** The coaxial input is your typical coaxial connector. We recommend using a 75 ohm digital cable when using the coaxial input. Please visit our website at [headphone.com](http://headphone.com) for various coaxial cables. If your Coaxial cable is a standard size, you will need a mini adaptor that adapts a full size coaxial connector to a mini size, they are available for purchase on HeadRoom website, and are called *RCA-Mini Mono adaptor*.

**5. USB Input** The USB input gets its signal from a computer: laptop, desktop, or Micro DAC-Mobile PC; PC, Mac, or Unix. Most computers will instantly recognize the Micro DAC upon plugging it in, but occasionally some users may need to go into the audio preferences and select the "USB Audio Codec" as their primary sound device. You also may need to restart your music playing program (iTunes, Windows Media Player, etc) once the Micro DAC is plugged in.

## Micro DAC Features

- Multiple Digital Inputs
- +/-15V Power Supply
- DC coupled signal path, from input to output
- Discrete emitter follower output stage, biased into class A operation (the Diamond buffer)
- Resistors are low noise, low drift .1% metal film types
- Local device decoupling with low-ESR, tight tolerance PPS film capacitors
- Power supply decoupling with ultra low ESR electrolytics
- Shortest signal path possible, PCB routed with high-speed signal integrity and low noise in mind
- Multi-layer PCB with dedicated, low impedance power and ground layers

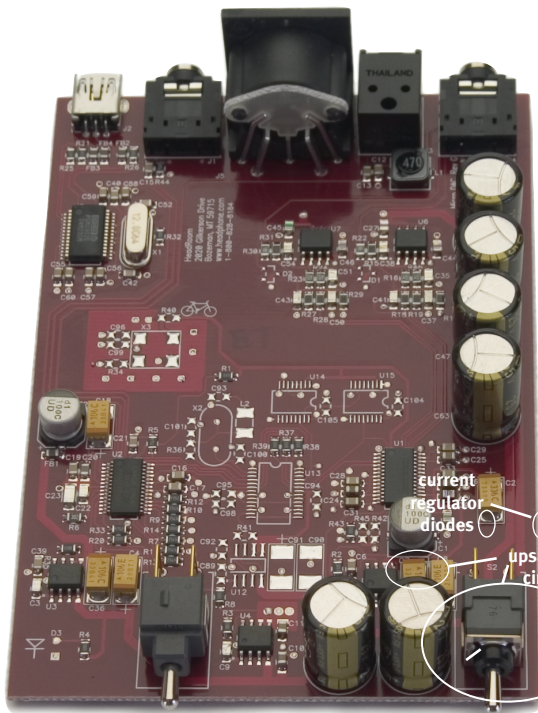

Micro DAC

## What is the HeadRoom Crossfeed?

Imagine you are listening to a pair of speakers. If you turn off the left speaker, both ears hear the sound from the right speaker. But because the left ear is slight farther away than the right ear, it hears the speaker's sound slightly after the right ear; about 300 microSeconds. This time difference is called the "inter-aural time difference" and it is the main thing your brain listens for in order to tell where to place sound left-to-right.

But in headphones if you turn off the left channel, only the right ear hears the sound. In headphones, if there is any sound that is only in the left channel, or only in the right channel, then only that ear hears the sound. This is not natural, and you brain becomes fatigued trying to figure out where sound is coming from when only one ear is hearing it. This tends to create an audio image that is a blob on the left, blob on the right and a blob in the middle.

HeadRoom amplifiers cure the problem by allowing you to cross-feed a little of the left and right channels across to each other through a short time delay using the crossfeed switch. The usefulness of the circuit varies depending on what type of recording you are listening to; mono and binaural recordings need no processor at all. Old studio recordings that have instruments panned hard left or right, benefit greatly from the processor. Live and classical recordings miked from a distance benefit somewhat less, and can often be listened to without the processor quite comfortably.

The crossfeed switch in HeadRoom amplifiers allow you to cross-feed a little of the left and right channels across to each other through a short time delay.



Plain  
Headphones



With  
HeadRoom

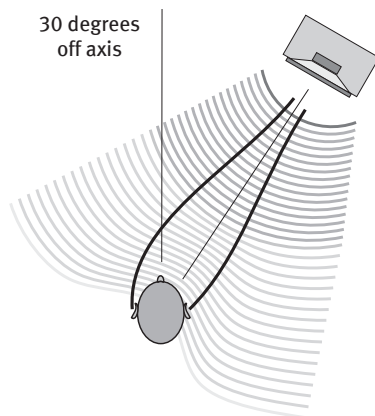

Far ear  
hears  
slight delay.

Near ear  
hears sound  
first.

# Connecting Your Micro DAC

## Connecting to your Computer:

The most convenient and common way to get a high quality signal out of your computer is with USB output. (If you have optical or coaxial outputs on your machine, then skip to the next section.) Simply plug a USB cable into your computer, and plug the smaller end into the back of the amp. In most cases your computer will instantly recognize the amplifier, but you will need to restart your music management program. If your computer does not recognize the device, restart; if it still is not recognized, you may need to go into your control panel/audio devices or system preferences/sound output and select 'USB Audio Codec' as your default audio device.

- Switch the Digital Input Selector Switch to 'USB'.

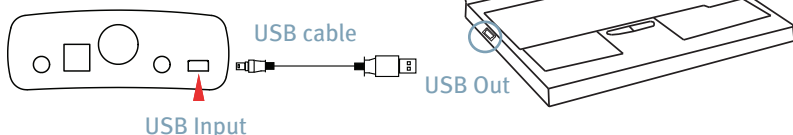

## To a portable DVD player with Optical Output:

You will need an appropriate optical cable, visit [headphone.com](http://headphone.com) to purchase a cable. Plug one end into your source and connect the other end into the appropriate input on the back of the amp. (Some DVD players may require you to turn on or activate the optical output.)

- Switch the Digital Input Selector Switch to 'optical'.

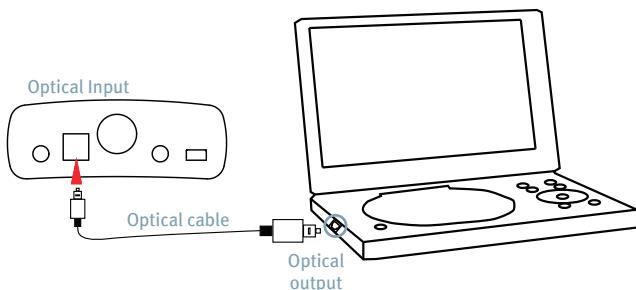

## To a Home CD player with a Coaxial output:

You will need an appropriate coaxial cable, visit [headphone.com](http://headphone.com) to purchase a cable. Plug one end into your source and connect the other end into the appropriate input on the back of the amp. If your Coaxial cable is a standard size, you will need a mini adaptor that adapts a full size coaxial connector to a mini size, they are available for purchase on HeadRoom website, and are called *RCA-Mini Mono adaptor*.

- Switch the Digital Input Selector Switch to 'coaxial'.

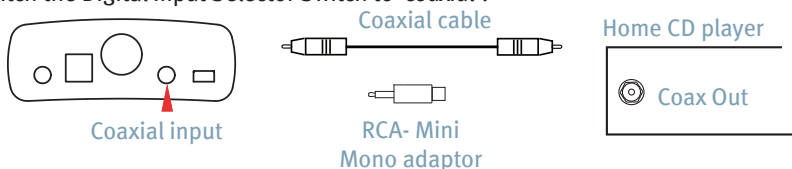

# Connecting your Micro DAC to an Amp

## Connecting Micro DAC to Micro Amp:

Your Micro DAC should be used with a headphone amp to properly drive your headphones with authority. HeadRoom's Micro Amp is designed to be used with the Micro DAC, but any amplifier with a line input will follow these same instructions.

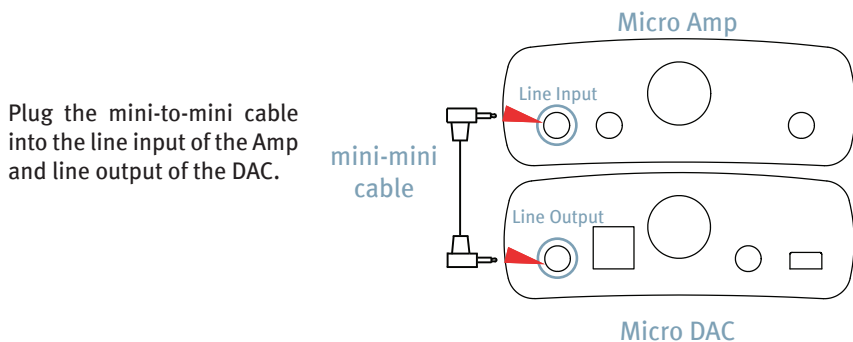

## Connecting Micro DAC to Amp with RCA Inputs:

If you are using a different amp that has a line input, simply follow the instructions above. If you are using a headphone amp that provides RCA inputs, then you will need a mini-RCA cable. Plug the mini end into the output of the Micro DAC, and RCA inputs into the back of the amp (as always, red or 'R' denotes right channel).

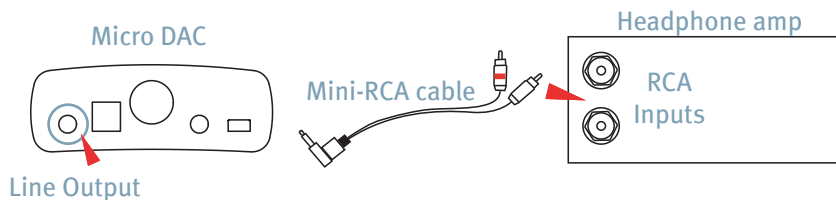

## Connecting headphones to Micro Amp:

You can connect any 1/8" (mini) headphone plug into the headphone output of your Micro Amp. (An adaptor is needed if your headphones are terminated to a 1/4" plug.)

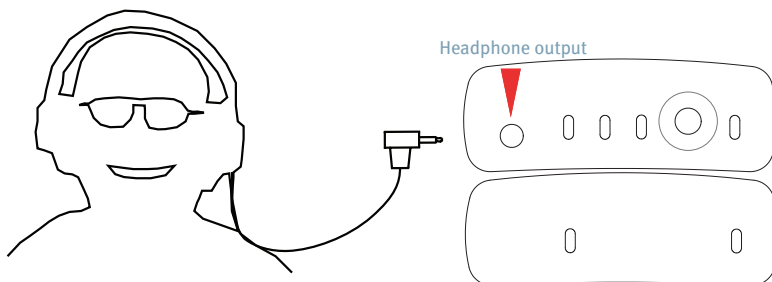

## 30 Day Guaranty & Warranty

### HeadRoom 30 Day Guaranty

Unless specifically stated otherwise, all HeadRoom purchases come with a 30-day satisfaction guaranty in order to give you the opportunity to evaluate your purchases. We're happy to provide you with the opportunity to refund or exchange your product, but to keep costs down we do have a few conditions. Products must be returned to us within 30 days of the date you receive the product. So make sure you try your purchase out right away! Products must be in "as-new" condition. This means that they're in pristine cosmetic condition, functioning perfectly, and include ALL materials (plastic bags, warranty cards, tie wraps, etc). In other words, please send products back exactly as you received them. If a product is returned within the 30-day return period, but is not in "as-new" condition, we will charge you a 15% restocking fee plus any labor and materials required to return the product to "as-new" condition. Sorry, but after your 30 day trial, products are no longer exchangeable or refundable.

If you're having trouble with a headphone amp or system, please contact us first to troubleshoot the problem. You can email Sales, ([sales@headphone.com](mailto:sales@headphone.com)) or call 800.828.8184. If we can fix it while you've still got the product, everyone's happy!

### Micro DAC Warranty:

The HeadRoom Micro DAC and are warrantied for two years. If anytime within the first two years of your purchase you have a problem with your Micro Products, you can return it for repairs under the terms of our 30 Day Guaranty. HeadRoom is the only authorized service center for HeadRoom products, either in or out of warranty. If a unit is under warranty, there is no cost for the repair labor, parts, or shipping from HeadRoom back to you (i.e., You're responsible for paying the shipping charges to get the product to us).

### Out of Warranty Repairs

If you have an older HeadRoom amp that is out of warranty, call us at 800.828.8184 ext.104 or email [service@headphone.com](mailto:service@headphone.com) to troubleshoot the problem with our Service Department. Upgrades fees are calculated by labor and parts costs. HeadRoom's non-warranty repair rate is \$100 per hour (billed in 1/2 hour increments) plus parts. If the cost of the repair is over \$100, we will call you with an estimate. Repairs are conducted only on HeadRoom products. When we receive the equipment, we will initiate repairs and upgrades within 1-2 weeks and return the unit to you. You are responsible for shipping costs to and from HeadRoom for all non-warranty repair items.

## Exchanges & Returns

### Equipment Exchanges

If you would like to exchange your purchase for another item, you have two options. You can simply purchase the item you want, and send the item you don't want back for refund within 30 days of the original purchase (don't forget to fill out the back of the Return & Exchange card and include it with your return). We will refund your credit card after we receive the item. Or, you can send your product back as an exchange, and indicate the product you would like on the Return card. We will adjust your credit card accordingly and ship you the new item. Replacement products are shipped to you as soon as possible, typically within 3-5 days provided the replacement item is in stock.

### Defective Equipment Exchanges

In the uncommon event of receiving a defective product, contact us and we will ship out a replacement product to you at no cost as soon as possible, typically within 3-5 days provided the replacement item is in stock. You will receive the replacement item along with a return shipping label and a card to include with the defective item to return to HeadRoom. Important: Fill in your name and original invoice number of your order on the card and return the item to HeadRoom within 2 weeks. If we have not received the product after 2 weeks (allowing shipping time) we will charge your credit card the amount of the defective item. Please understand that we enforce this policy as an incentive for customers to get defective equipment back to us as soon as possible.

### Shipping Products back to HeadRoom

Please ship products back in the original shipping box (or another that is comparable); please don't send headphones back in JUST the headphone box, as it's a sure bet that they will no longer be in "as-new" condition when we receive them! We HIGHLY recommend that you ship returns using an insured and "signature required" delivery method—we can't be responsible for lost or damaged packages. Finally, don't forget to include the completed Return & Exchange card and WRITE YOUR NAME on the outside of the box!

#### Return Products to:

HeadRoom  
Attn: Returns  
2020 Gilkerson Drive  
Bozeman, MT 59715

#### Contact Us:

[www.headphone.com](http://www.headphone.com)  
Toll Free: 800-828-8184  
Phone: 406-587-9466  
Fax: 406-586-9484



## A Word About Your Hearing

People have a natural tendency to listen to music at much louder levels with headphones than they would with speakers. To avoid permanent hearing damage, it's important to be careful not to listen at extremely loud levels (or to listen for too long at moderately loud levels). Because HeadRoom amps need to be able to drive even the most inefficient dynamic headphones to satisfactory listening levels, they are also able to drive headphones of average or higher efficiencies to extremely high levels. As a result, even though the volume control on your HeadRoom amp may appear to be set to a low level, you may not be listening at a safe level. Generally speaking, when listening to headphones you should only turn up the volume to the point at which the sound isn't too quiet.

As a general rule, sound pressure levels under 80 decibels will not damage hearing, even if experienced continually. On the other hand, anything over 100 decibels may cause permanent damage very quickly. Sustained exposure to sound pressure levels anywhere in between can also be damaging—the louder the sound, the shorter the time required to cause permanent damage. Just to drive this message home, here's a bit of information about hearing damage. The most common type of damage caused by prolonged or excessively loud sound is called tinnitus. It manifests itself as a sustained buzzing and/or ringing in the ears, and can become a permanent condition.

If you find that your ears are ringing or that there is a sensation of pressure or fatigue, your body is trying to tell you that your ears need a break. Give them a rest for a few days (or until they feel fresh). If you ignore these symptoms, you're risking permanent hearing damage.

In addition, don't fool yourself into thinking that you either have full-blown tinnitus or you don't have it at all—there are different degrees of hearing damage. For example, you might have a mild case where you only notice ringing in your ears in the quiet of your bedroom at night. However, once you have a slight case of tinnitus, your ears are much more susceptible to further damage. So if you do experience mild symptoms, it's important to be much more careful about your exposure to loud sounds.

Sorry to sound so sobering, but a lifetime of musical enjoyment requires ears in tiptop shape. Now that we've told you to be careful, don't blame us if you blow it. If you have any more questions about hearing damage, call a doctor.

### Contacting HeadRoom

Toll Free: 800-828-8184  
Phone: 406-587-9466  
Fax: 406-587-9484

2020 Gilkerson Drive  
Bozeman, MT 59715  
[www.headphone.com](http://www.headphone.com)